



Enso

Collection

boss

Enso

Modular Seating



Designed to shape more connected, adaptable and human-centred interiors, Enso is a modular seating and banquette system created for evolving hospitality, workplace and social environments.

Refined Comfort

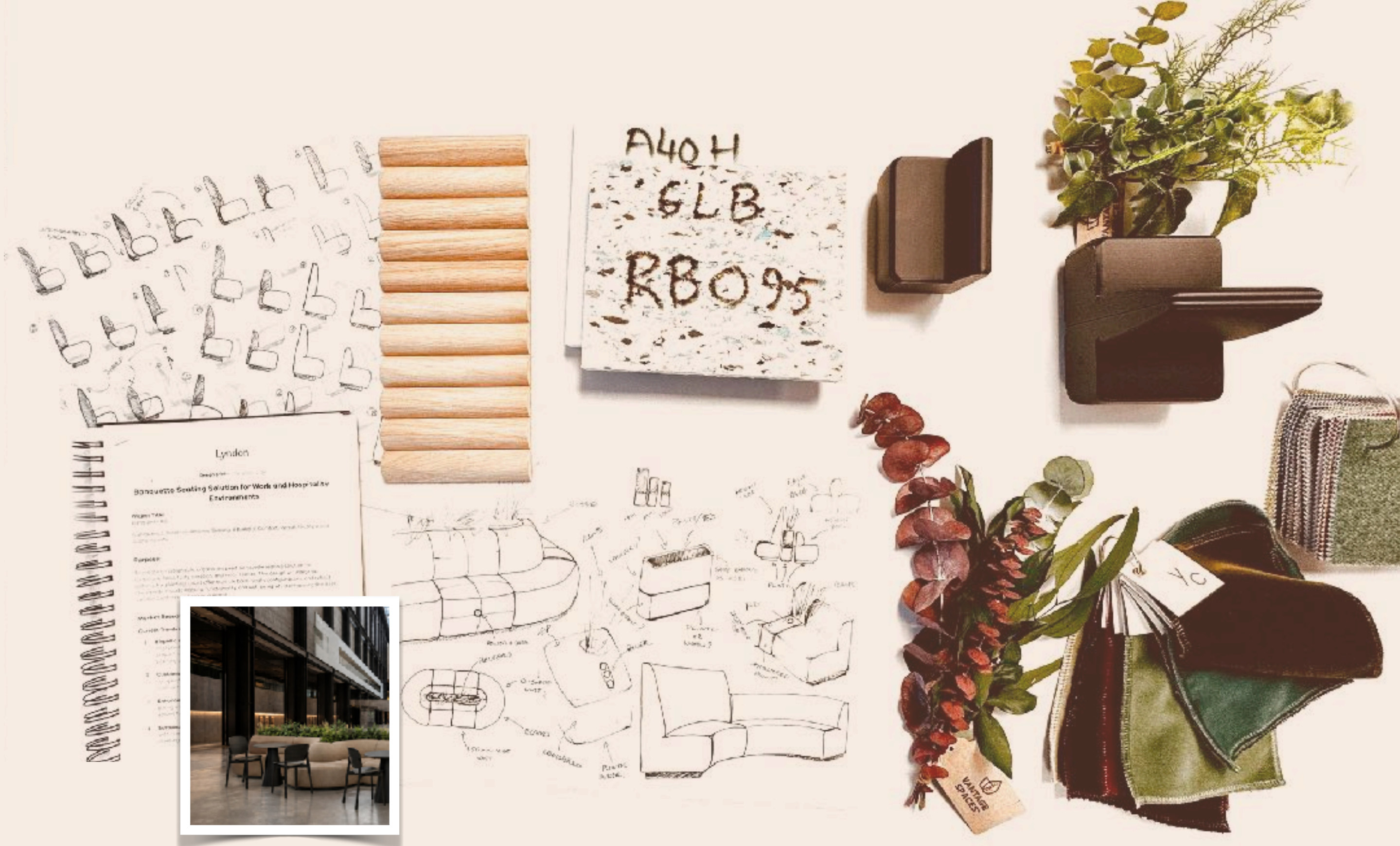

Soft architectural forms, integrated planting and a refined modular structure allow Enso to create destination spaces that feel both calm and purposeful. From informal collaboration zones and work cafés to hospitality lounges and transitional spaces, the collection brings flexibility, comfort and warmth into contemporary interiors.

Designed and made in the Cotswolds by Lyndon, Enso combines British craftsmanship with a more circular approach to furniture design, balancing longevity, adaptability and material responsibility within one considered system.

“Enso was designed to bring a softer, more natural rhythm into commercial interiors. The idea was to create a modular system that could shape space architecturally, while still feeling calm, welcoming and highly comfortable.

We wanted the collection to feel flexible and intuitive, allowing designers to create everything from quiet retreat spaces to larger social settings through one coherent design language.”

Ethan Lee

Destination spaces shaped around comfort, connection and circular thinking.

Inspired by the fluidity of organic forms and the philosophy of connected spaces, Enso has been developed as a highly flexible modular platform. Curved and linear elements can be combined to create intimate booths, open social settings, quiet retreat spaces or larger architectural configurations tailored to the needs of each environment.

Integrated planter options introduce a softer biophilic layer to interiors, helping spaces feel calmer, more natural and more welcoming.





At the heart of Enso is our long-standing upholstery expertise. Deep cushioning, carefully proportioned backrests and refined upholstery detailing create a level of comfort more commonly associated with hospitality interiors than traditional contract furniture.

Every piece is manufactured with the attention to detail, tailoring and craftsmanship that has defined us for generations.





Enso has been developed with longevity and responsible material selection in mind. The collection uses fully recycled Orbis foam sets from The Vita Group, derived from post-consumer waste streams and designed to support a more circular material lifecycle. Modular construction allows sections to be reconfigured, refreshed or renewed over time, helping extend product life and reduce unnecessary replacement.

Integrated power and data options further support long-term adaptability across workplace and hospitality settings.

Modular

Bespoke

Enso has been developed as a highly flexible modular system, offering a broad range of curved and linear elements that can be configured to suit everything from intimate hospitality settings to workplace and public environments. Low-back modules create open, collaborative layouts that encourage movement and interaction, while high-back configurations provide greater levels of comfort, enclosure and acoustic privacy for focused work, informal meetings or quieter retreat spaces.

Alongside the standard modular collection, Enso can also be tailored through Lyndon's bespoke manufacturing capability to respond to the exact requirements of a project. Dimensions, configurations and layouts can be adapted to fit architectural features, circulation routes or unique spatial challenges, allowing designers to create seamless integrated seating solutions with the same level of craftsmanship, comfort and design integrity found throughout the collection.



Enso

Configurations



FEATURES

Modular curved and linear seating elements

Hospitality-led comfort and refined upholstery detailing

Integrated planter options for biophilic environments

Recycled Orbis foam

Power and data integration available

Off-the-floor upholstery design for improved longevity and maintenance

Configurable for workplace, hospitality, aviation and public environments

Designed for adaptability, renewal and long-term use

Designed and manufactured in the Cotswolds UK

Enso

Collection



Enso

Collection

Low Back

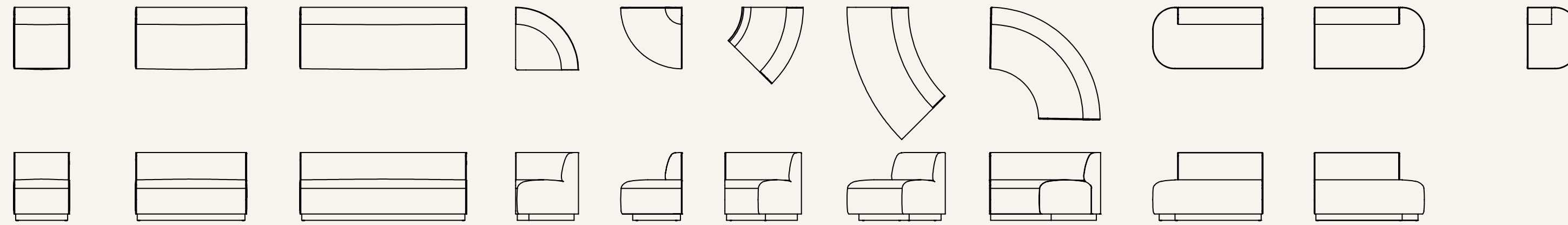

ENS/LB/650	Enso Low Back, 650mm straight unit
ENS/LB/1300	Enso Low Back, 1300mm straight unit
ENS/LB/1950	Enso Low Back, 1950mm straight unit
ENS/LB/END/700/RH	Enso Low Back, 700mm RH end unit
ENS/LB/END/700/LH	Enso Low Back, 700mm LH end unit
ENS/LB/END/1290/RH	Enso Low Back, 1290mm RH end unit
ENS/LB/END/1290/LH	Enso Low Back, 1290mm LH end unit
ENS/LB/END/180	Enso Low Back, 180 degree D-end unit
ENS/LB/IC/45	Enso Low Back, Inward Curve 45 degree connecting unit
ENS/LB/IC/90	Enso Low Back, Inward Curve 90 degree corner connecting unit
ENS/LB/IC/R1300	Enso Low Back, Inward Curve R1300mm unit
ENS/LB/OC/45	Enso Low Back, Outward Curve 45 degree connecting unit
ENS/LB/OC/90	Enso Low Back, Outward Curve 90 degree corner connecting unit
ENS/LB/OC/R1480	Enso Low Back, Outward Curve R1480mm unit
ENS/LB/DUAL/650	Enso Low Back, Dual 650mm straight unit
ENS/LB/DUAL/1300	Enso Low Back, Dual 1300mm straight unit
ENS/LB/DUAL/1950	Enso Low Back, Dual 1950mm straight unit
ENS/LB/DUAL/45	Enso Low Back, Dual 45 degree curved unit
ENS/LB/DUAL/END/180	Enso Low Back, Dual 180 degree D-end unit

Dual

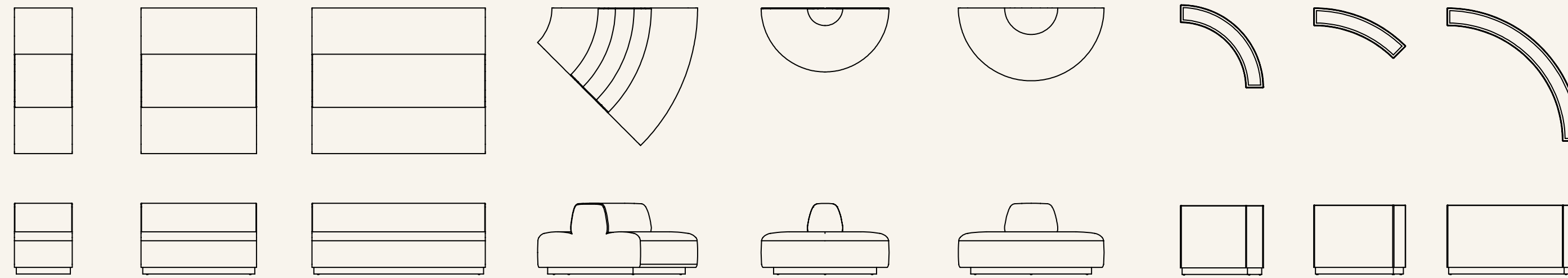

High Back

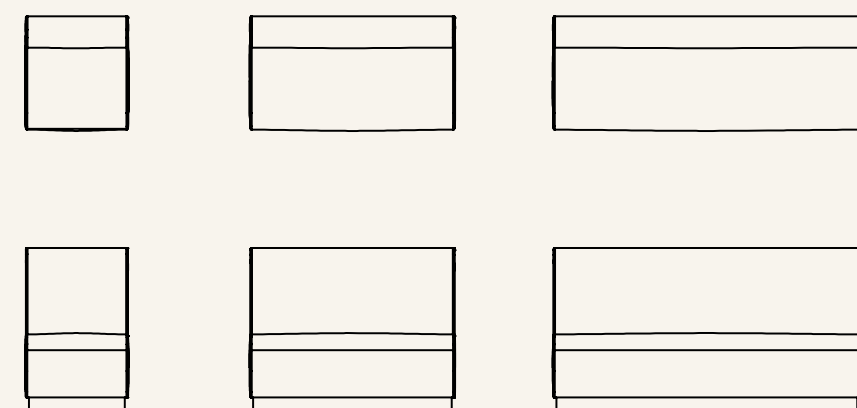

ENS/HB/650	Enso High Back, 650mm straight unit
ENS/HB/1300	Enso High Back, 1300mm straight unit
ENS/HB/1950	Enso High Back, 1950mm straight unit

Enso

Collection

Planter

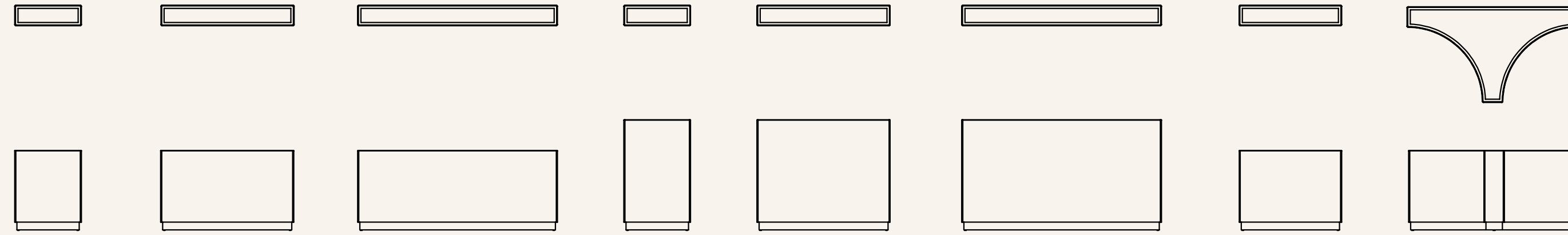

ENS/PLANT/LB/650	Enso Planter, Low Back, 650mm straight
ENS/PLANT/LB/1000	Enso Planter, Low Back, 1000mm straight
ENS/PLANT/LB/1300	Enso Planter, Low Back, 1300mm straight
ENS/PLANT/LB/1950	Enso Planter, Low Back, 1950mm straight
ENS/PLANT/LB/IC/45	Enso Planter, Low Back, Inward Curve 45 degree
ENS/PLANT/LB/IC/90	Enso Planter, Low Back, Inward Curve 90 degree
ENS/PLANT/LB/IC/R1300	Enso Planter, Low Back, Inward Curve R1300mm
ENS/PLANT/LB/DUAL/T/L	Enso Planter, Low Back, Dual T-Large
ENS/PLANT/HB/650	Enso Planter, High Back, 650mm straight
ENS/PLANT/HB/1000	Enso Planter, High Back, 1000mm straight
ENS/PLANT/HB/1300	Enso Planter, High Back, 1300mm straight
ENS/PLANT/HB/1950	Enso Planter, High Back, 1950mm straight

boss

www.bosssdesign.com